



BEVERAGE-AIR

Project: _____

AIA#

Item: _____

Location: _____

SIS#

Approved: _____

MARKETEER™ MERCHANDISERS

MT23 White Hinged Door Model
Hydrocarbon Series

MODELS:
MT23-1W

MT23™ MERCHANDISER: HINGED DOOR MODEL



3 Year Parts/Labor Warranty
Additional 4 Year Compressor Warranty

CABINET CONSTRUCTION

- Standard cabinet exterior finish is heavy duty steel with a white baked on durable coating
- Heavy duty interior construction includes white coated steel
- Electronic temperature control
- Modern one piece grill
- Double pane lowE argon filled glass doors feature outside pane that is tempered for added safety
- Door lock standard
- Self-closing hinged glass door features, pocket door handle
- LED lighting
- Five (5) epoxy coated shelves standard.
- 2" Leveling feet

OPTIONS & ACCESSORIES

- Extra shelves & clips
- 3" Casters
- Visislide shelving kit

REFRIGERATION SYSTEM

- Uses environmentally friendly, energy efficient R290 refrigerant, and meets all regulatory requirements for CARB, SNAP, DOE & more
- Condenser is designed to be low maintenance, and energy efficient.
- Automatic, non-electric defrost
- Epoxy coated evaporator coil



Please verify qualifying units by visiting:
www.energystar.gov/cfs

3779 Champion Blvd., Winston-Salem, NC 27105
1-888-845-9800 Fax: 1-336-245-6453
Beverage-Air.com Sales@bevair.com



BEVERAGE-AIR

| MODEL | MT23-1W |
|----------------------------------|-------------------|
| EXTERNAL DIMENSIONAL DATA | |
| Width Overall | 29 9/16" |
| Depth Overall | 26 1/8" |
| Height Overall | 78 5/8" |
| Number of Doors | 1 |
| Depth with Door Open 90 ° | 53 7/8" |
| Clear Door Opening (in) | 25 5/8" x 60 1/4" |
| Shelf Area (Sq. in) | 486 15/16" |
| INTERNAL DIMENSIONAL DATA | |
| NET Capacity (cubic ft.) | 19.20 |
| Capacity 20 oz. | 240 |
| Internal Width Overall (in) | 25 1/2" |
| Internal Depth Overall (in) | 19 3/8" |
| Internal Height Overall (in) | 60 1/2" |
| Internal Height Useable (in) | 50 3/8" |
| Number of Shelves | 5 |
| ELECTRICAL DATA | |
| Full Load Amperes 115/60/1 | 7 |
| REFRIGERATION DATA | |
| Horsepower | 1/3 |
| Capacity (BTU/Hr)* | 2274 |
| SHIPPING DATA | |
| Gross Weight - Crated | 246.91 lbs |
| Height - Crated | 84 5/8" |
| Width - Crated | 32 1/8" |
| Depth - Crated | 29" |

Glass Hinged Door Model

Models: MT23-1W

Model Views

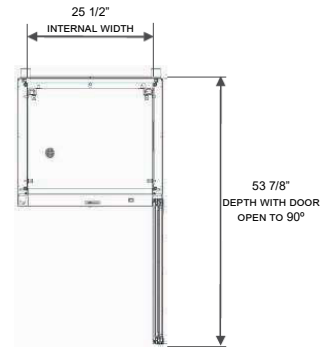

Plan View

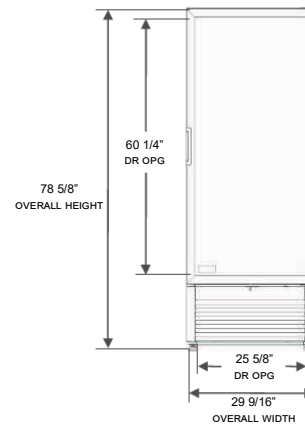

Elevation View

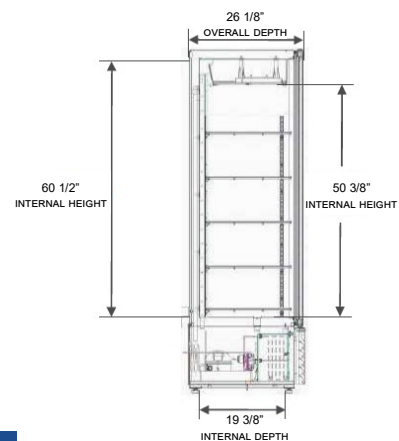

Side View

ELECTRICAL CONNECTION



115/60/1
NEMA-5-15P

Units pre-wired at factory and include 8' long cord and plug set.



3779 Champion Blvd., Winston-Salem, NC 27105 1-888-845-9800 Fax: 1-336-245-6453 Beverage-Air.com Sales@bevair.com

an Ali Group Company



The Spirit of Excellence